

TECHNICAL DOCUMENTATION	1/06/2004	GAUGE	MyChron 3 KART EXTREME
MyChron 3 KART EXTREME Technical documentation, dimensions and pinout Ver. 1.02			

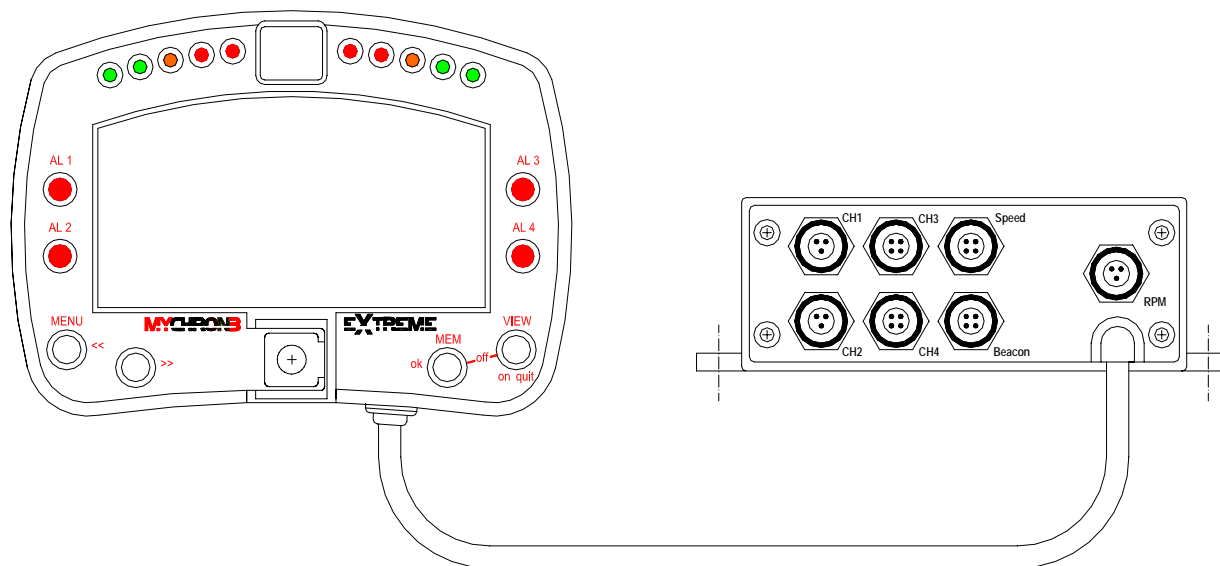

Figure 1: MyChron 3 Kart Extreme

Introduction

MyChron 3 KART EXTREME represents the new generation of Aim data acquisition systems that provides the karter with a sophisticated and easy to read display normally reserved for premium sports cars, and an external Junction Box connected to the display unit through a 1000 mm long cable. The user will have to plug all the sensors in this Junction Box.

MyChron 3 KART EXTREME monitors and displays RPM, two separate temperature inputs, two other analog inputs (temperature, pressure, potentiometers) wheel speed, gear number and lap (split) times. It also has a backlight, which can be switched on during night racing.

The logger records the following parameters:

- 2 temperature input (cooling water, cylinder head or exhaust gas);
- 2 analog inputs: pressures, temperatures, potentiometers;
- engine's RPM;
- lap and split times;
- gear number;
- 1 speed input;
- lateral acceleration, mounted inside the Junction box;
- logger battery voltage;
- logger temperature;

Data are stored in a huge internal 8 Mbyte memory and downloaded to a PC through an USB cable.

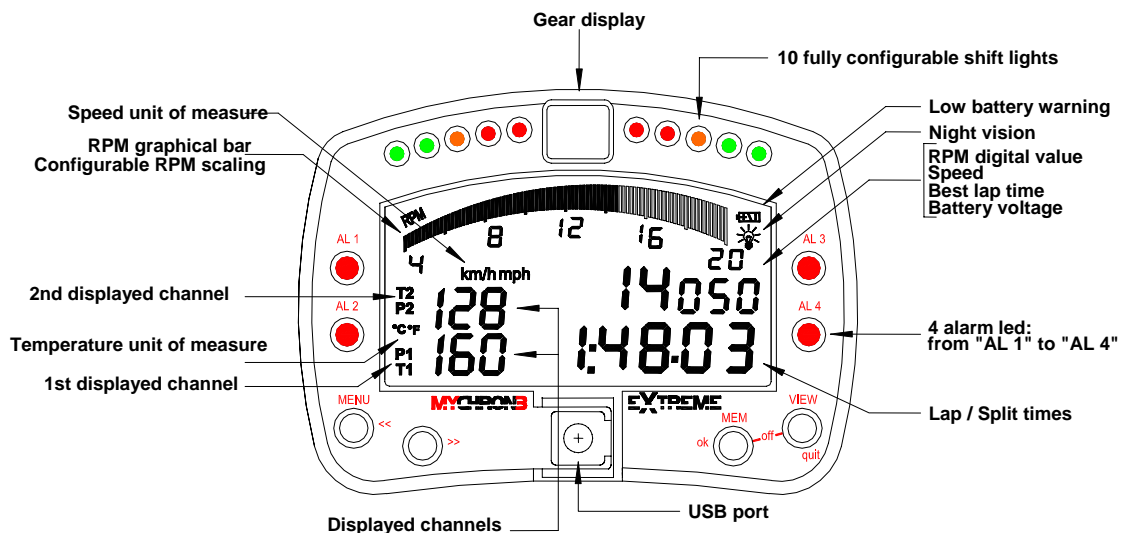
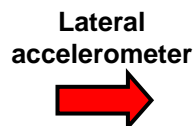
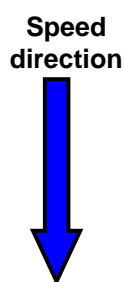

Figure 2: MyChron 3 Kart Extreme Display

Installation notes

- Most of steering wheels have existing holes in the 3 central arms that will accommodate your **MyChron 3 KART EXTREME** display unit;
- If the steering arms are solid, mark the point where the hole is to be drilled and then indent a drill reference point with a large nail or hole punch, to minimize drill wander;
- Do not over-tighten the locknut: over-tightening the nut may seriously damage the display unit chassis;
- It is suggested to use plastic washers, furnished as equipment, to keep separate your **MyChron 3 KART EXTREME** from the steering wheel;
- Once the display unit has been installed, it is possible to install the Junction box under the number plate. Avoid rigid connections between the Junction Box and the chassis: in case you want to install the Junction box on the kart's platform, use antivibration mountings;
- Once the gauge has been correctly installed, please plug the sensors in the connectors on the Junction Box's front panel.



In order to correctly measure the lateral g-force using the internal accelerometer, it is recommended to install the gauge with the Junction box's front panel perpendicular to the vehicle's speed.

How to connect MyChron 3 KART EXTREME to the PC

In order to connect your **MyChron 3 KART EXTREME** to the PC, please use the USB data download cable and plug it both in the gauge's USB port and in the PC's USB port, as explained in the following drawing.

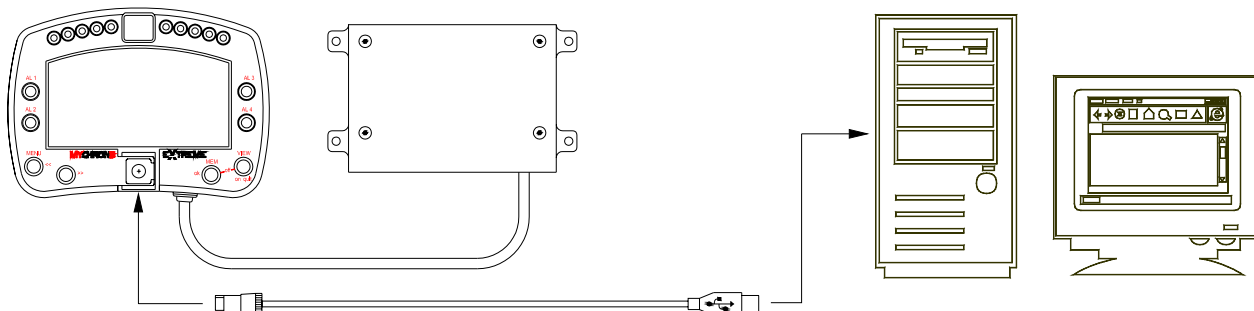

Figure 3: How to connect MyChron 3 Kart Extreme to the Pc

Software

Once the data logger installed and the sensors plugged in it, it is necessary to configure the data logger to acquire consistent and correct information,. For a correct configuration, please use **Race Studio 2**, the software developed by Aim to configure its instruments and analyze stored data.

Race Studio 2

In **Race Studio 2** main window, reported here above, You can choose your data logger. Once selected the gauge, please press “New” and then “System manager”.

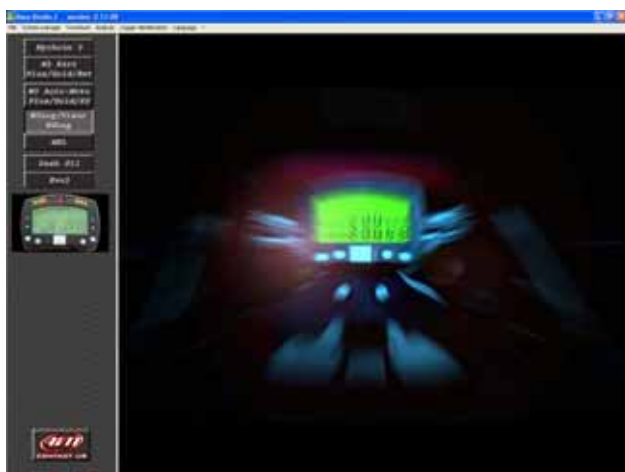

Data logger configuration

Once reached the “System manager” main window, please press “configuration” button to set RPM maximum value, temperature measure unit, RPM factor, the split numbers etc... The following screenshot appears.



To configure **MyChron 3 KART EXTREME**, please set all parameters of the dialog box:

- Display language: messages can be displayed in 6 languages: Italian, English, German, French, Spanish and Slovenian.
- RPM multiply factor: this option sets the number of spark signals per engine revolution. For a 2-stroke, one cylinder engine, the correct value is “x1”; Maximum RPM value: sets maximum scale for the graphical RPM display and maximum RPM value acquired by your MyChron 3. The user may choose among 7 values: 8000, 10000, 12000, 16000, 20000, 22000 and 25000 RPM (“RPM” box top on the right).
- Temperature and speed measure unit: °C or °F and km/h or Mph (“Measure Units” box bottom left).
- Thresholds values for the temperature (channels 1 and 2) and the other (channels 3 and 4) sensors that trigger the 4 maximum/minimum alarm led (labelled AL. 1 to AL. 4). (“Channel” box lateral)
- Wheel circumference: this value is used to correlate the wheel rotational speed with the kart’s speed. Pulses per wheel revolution: this option sets the number of electrical pulses captured by the speed sensor per wheel revolution. Together with the wheel circumference, is fundamental to acquire the correct kart speed (“Speed” box top left).
- Obscuring time: this option sets the time during which the lap receiver (optic or magnetic) is “obscured” and it is not able to capture lap markers. This option is useful if you do not wish to capture split times on a track where more than one beacon transmitter (or magnetic strip) is positioned: in this case, please set the obscuring time to a value of about 5 second lower than the track best lap time.

Otherwise, if you wish to capture split times, please set this parameter to a low value: the min. value accepted by the instrument is 3 seconds, the maximum value suggested is 8 seconds. Number of splits: this function sets in how many split times you wish to divide your track. This option is available only on tracks with multiple magnetic strips or with more than one beacon transmitter. Please, remember to fill this box with the number of splits and not with the number of magnetic strips (or beacon transmitters). “Lap” box bottom on the right

- Shift light: this option allows the user to set the five RPM values, each one corresponds to a coloured led. The five led switch progressively on in order to indicate the pilot to change gear (“Shift light” box top central).
- Gear sensor: the user may choose the gauge to calculate the engaged gear or to disable that input channel (“Gear Sensor” box bottom central).

Once these values have been set, it is necessary to transmit the configuration to the instrument by pressing the “Transmit” button.

Calibration procedure

The internal lateral g-sensor and the potentiometers (if installed) need to be calibrated. Once the configuration has been transmitted to the gauge, click the “Calibrate” button, please follow these instructions:

- The internal lateral G-force sensor and the “potentiometer distance” sensor need to be autocalibrated pressing button “Click here to autocalibrate all sensors in the list”.
- To calibrate, the “Mid zero potentiometer” or the “zero based potentiometer”, please click on the corresponding “Calibrate” button and follow the instructions prompted on your PC’s monitor.

Once the calibration procedure has finished, it is absolutely necessary to re-transmit the configuration to your data logger pressing the “OK” and then the “Transmit” button.

Dimensions

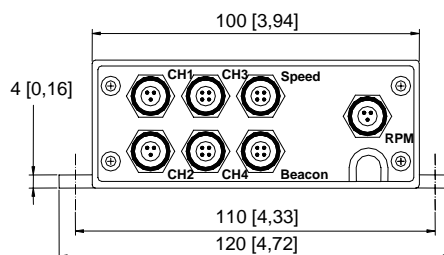
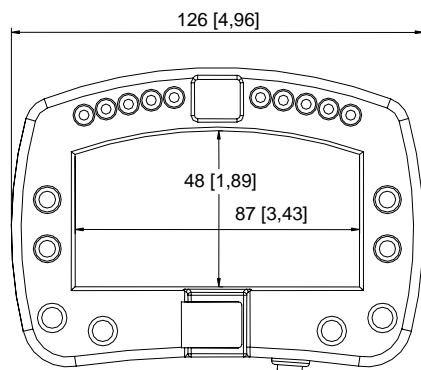

Dimensions in millimetres [inches]

Connector details (Beacon channel)

Pin	Function	Pin	Function
1	Magnetic lap	3	V battery
2	GND	4	Optic lap

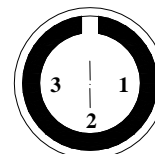
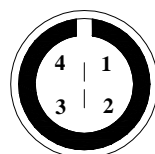

Female binder connectors pinout (external view): 4 pins (left) and 3 pins (right)

Connector details (Speed channel)

Pin	Function	Pin	Function
1	Speed signal	3	V battery
2	GND	4	n.c.

Connector details (RPM channel)

Pin	Function	Pin	Function
1	RPM: spark plug	3	n.c.
2	GND		

Connector details (Ch. 1 & Ch. 2)

Pin	Function	Pin	Function
1	Thermocouple	3	Thermo resist.
2	GND		

Connector details (Ch. 3 & Ch. 4)

Pin	Function	Pin	Function
1	Analog input	3	+ V battery
2	GND	4	V ref. (5 V)

Specifications

General characteristics	Value
Input channels	5
Internal battery	6 AAA 1.5 V, alkaline
Working time	About 40 hours of use
Internal memory	8 Mbyte
PC interface	300 kbyte/sec USB port
Sampling freq. per channel	10 Hz
Total sampling frequency	91 Hz
Internal g-sensor	±5 g
Voltage output	5 V

Other characteristics	Value
MyChron 3 PG dimensions	126x92x24 mm
Junction Box (JB) dimensions	100x39x71 mm
Display dimensions	85x50 mm
Environmental	IP 65
JB-Display unit cable	1000 mm